

Fan, PSU, & Idle Power in Air-/Direct-Liquid-Cooled Servers

August Ning, Xavier Ouvrard, Babak Falsafi
 {august.ning, xavier.ouvrard, babak.falsafi}@epfl.ch

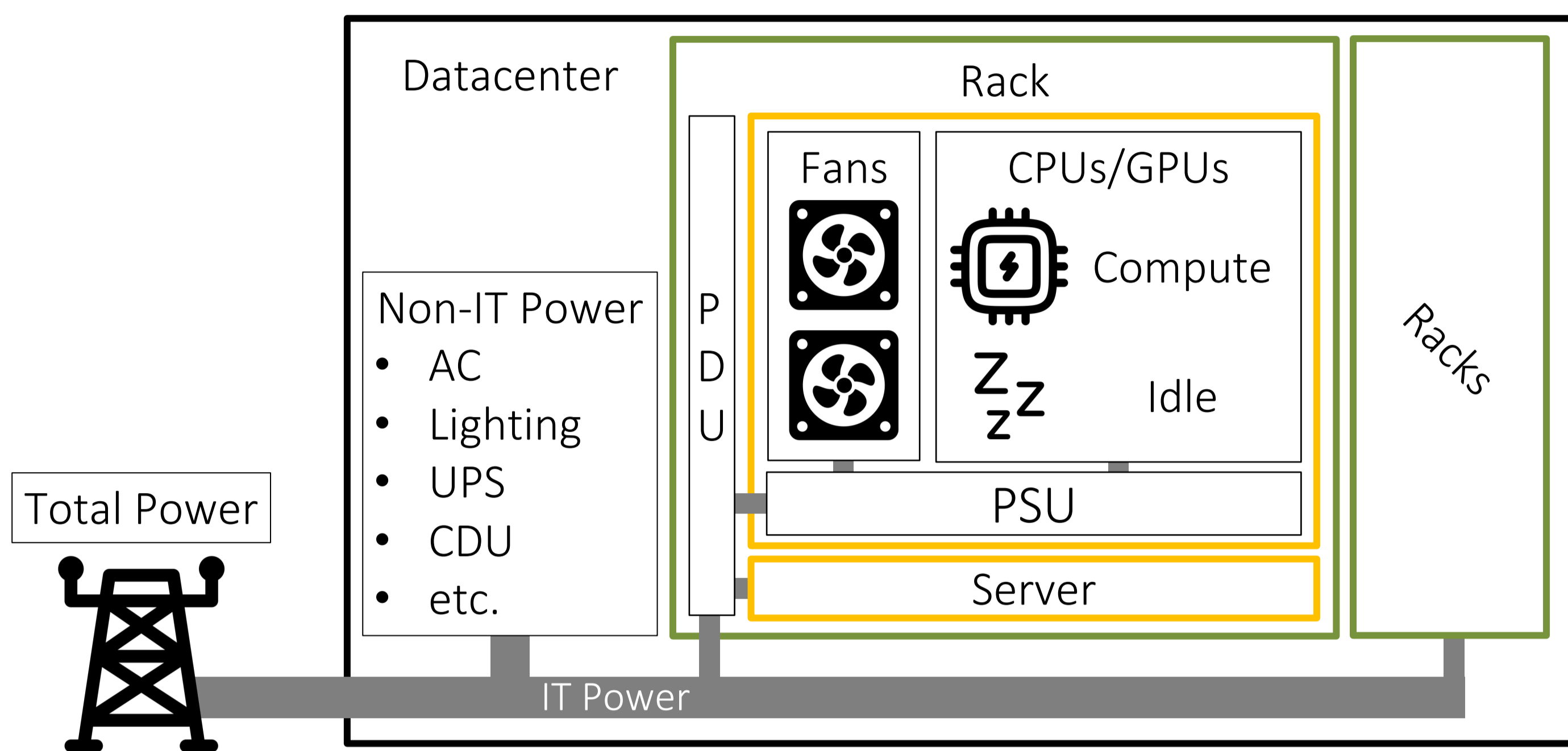

Datacenter Power, PUE, and IUE



$$\text{Power Usage Effectiveness (PUE)} = E_{\text{Total}} / E_{\text{IT}}$$

$$E_{\text{IT}} = E_{\text{PSU}} + E_{\text{Fans}} + E_{\text{Idle}} + E_{\text{Compute}}$$

$$\text{Infrastructure Usage Efficiency (IUE)} = E_{\text{Compute}} / E_{\text{IT}}$$

Experimental Setup

Break down and characterize server power

Experiments done at EPFL EcoCloud

Server	HPE ProLiant DL380 Gen11
CPU	Dual Socket Intel Sapphire Rapids Dual Socket AMD Zen 4
RAM	256 GB
Fans	High Performance Fan Kit (6x fans)
DLC CDU*	CoolIT CHx200
PSU	2x HPE Artesyn PSU
PDU	RNX RN3517

*Direct liquid cooling is CPU only

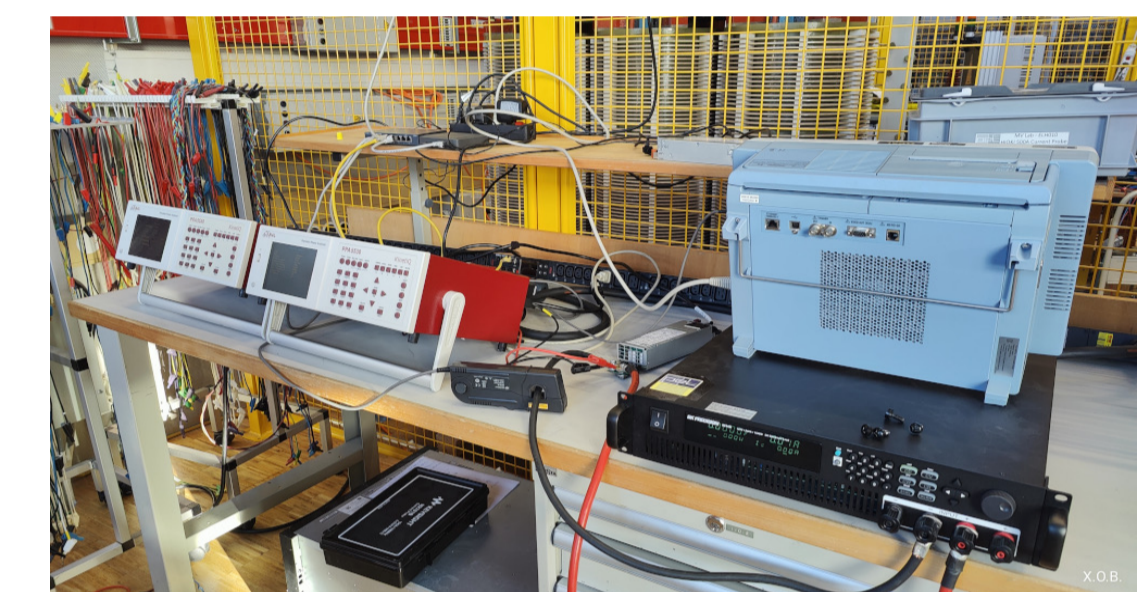

EcoCloud servers and PSU measurement setup

Server Power Breakdown

PSU Loss

PSU yield varies by load

Load PSU	Power PDU	Power PSU _{in}	Power PSU _{out}	Yield PSU
160W (10%)	179	179	158	0.886
320W (20%)	346	345	319	0.924
480W (30%)	514	513	482	0.936
640W (40%)	686	685	645	0.941
800W (50%)	861	860	808	0.940
960W (60%)	1040	1039	973	0.936
1120W (70%)	1224	1223	1139	0.931
1280W (80%)	1413	1410	1306	0.926
1440W (90%)	1608	1604	1473	0.918
1500W (limit)	1686	1682	1536	0.913

Fan Power

Fan power \propto (fan speed)³

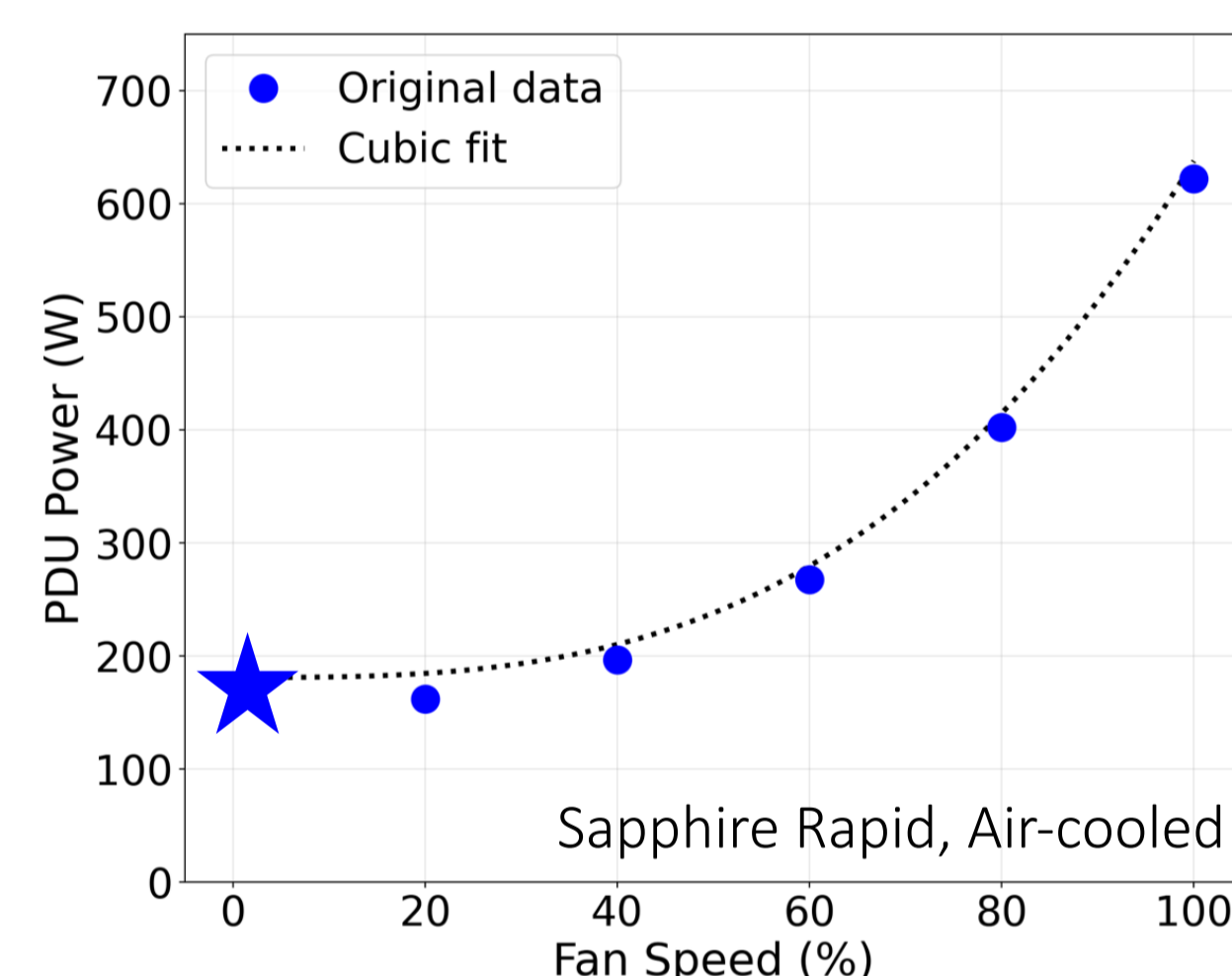

Fan Speed	20%	40%	60%	80%	100%
Fan Power	3W	28W	93W	221W	432W

Idle Power

Idle power = server power with no compute load and no fan load

IPMI limits min. fan speed
 ↓
 Sweep fan speed and extrapolate no fan load PDU power
 ↓
 Subtract PSU yield loss

	Sapphire Rapids Air-Cooled	Sapphire Rapids DLC	Zen 4 Air-Cooled
PDU	180W	190W	210W
Idle Power	155W	165W	182W

Compute Power

Increase CPU load with stress-ng benchmarks

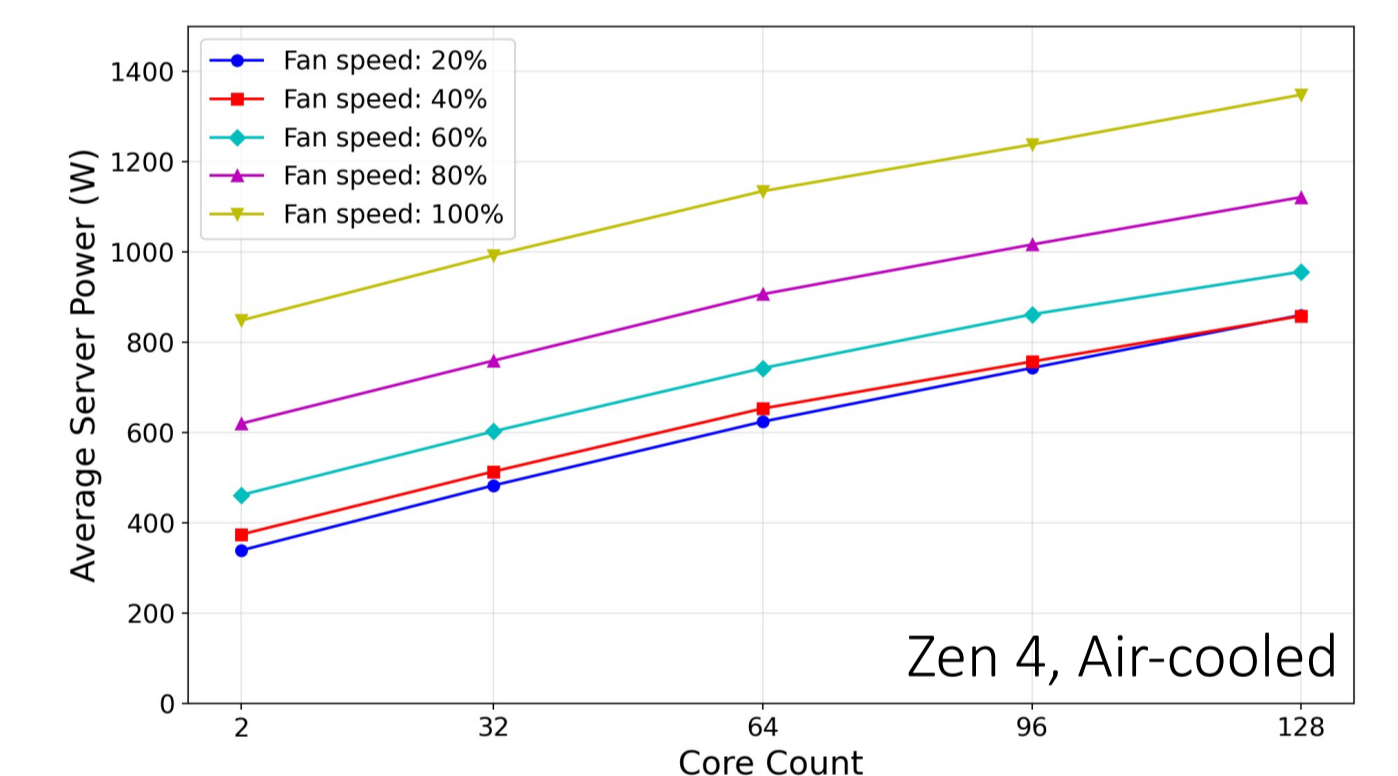

Use Case	PUE* (24°C)	Server Util.	DLC Fan Speed	DLC CDU Power†
Hyperscaler	1.1	60%	20%	20W
Co-location	1.3	15%	20%	20W

*Assuming identical racks and cooling solutions throughout the datacenter, negligible PDU loss
 †Assuming 200W CDU pump power for a 20kW rack with 10 servers

Ambient Temperature Study

DC operators are interested in increasing ambient temps (32°C)

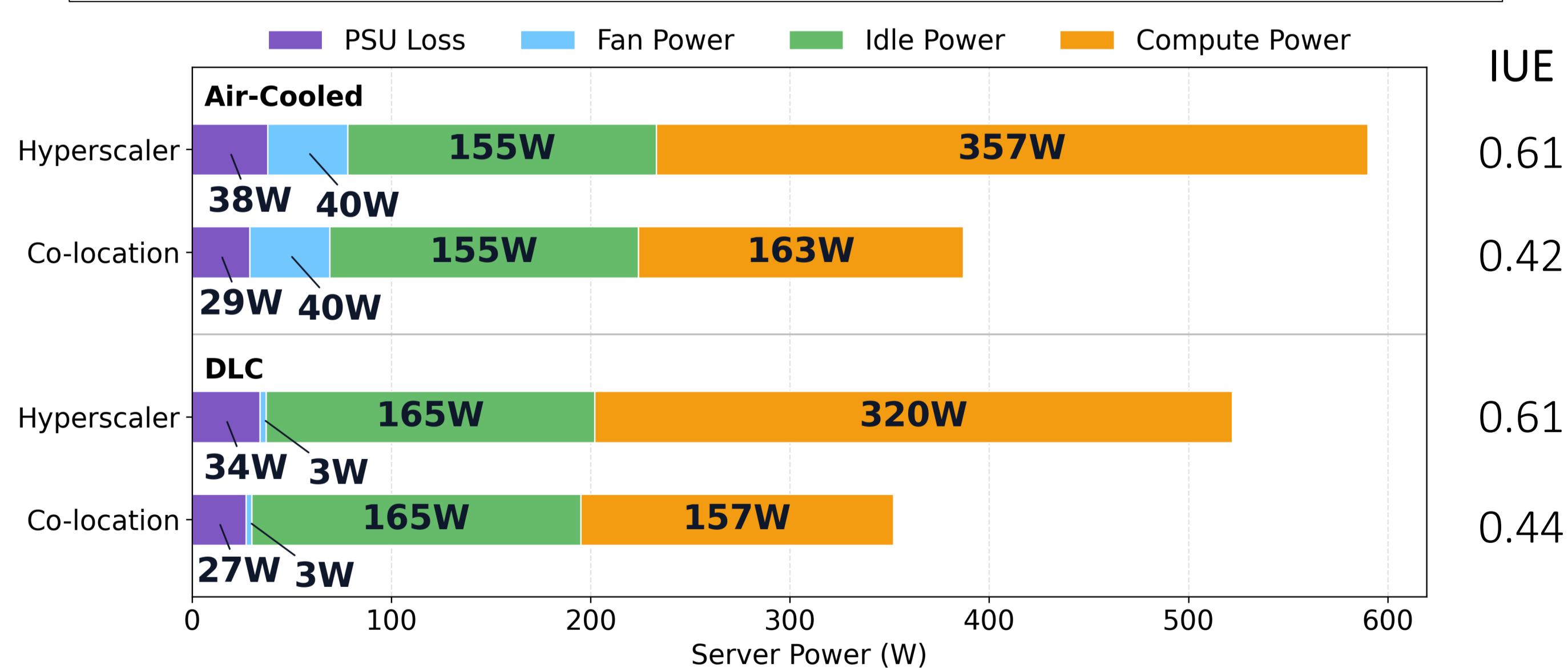

Fan power becomes > 10% of total server power for co-located servers when operating at high ambient temps

Increasing fans from 20% to 45% → 10x fan power

Idle power ranges 26% to 46% of total server power

Fan-Adjusted PUE

$$\text{PUE} = (E_{\text{IT}} + E_{\text{non-IT}}) / E_{\text{IT}}$$

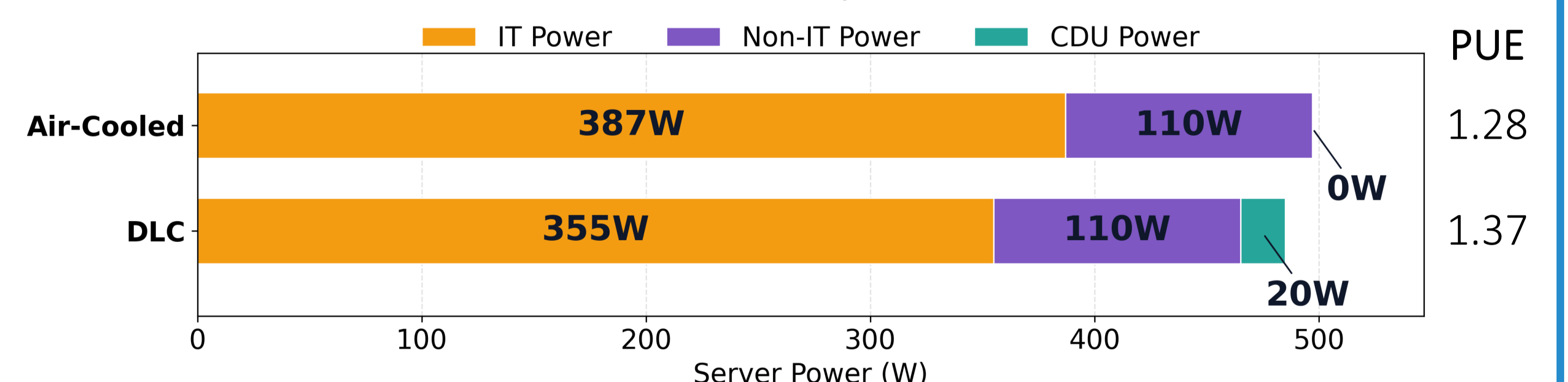

At higher ambient temps, increased fan power decreases PUE

DLC has higher PUE despite using less overall power!

$$\text{PUE}_{\text{FA}} = (E_{\text{IT}} + E_{\text{non-IT}}) / (E_{\text{IT}} - E_{\text{fans}})$$

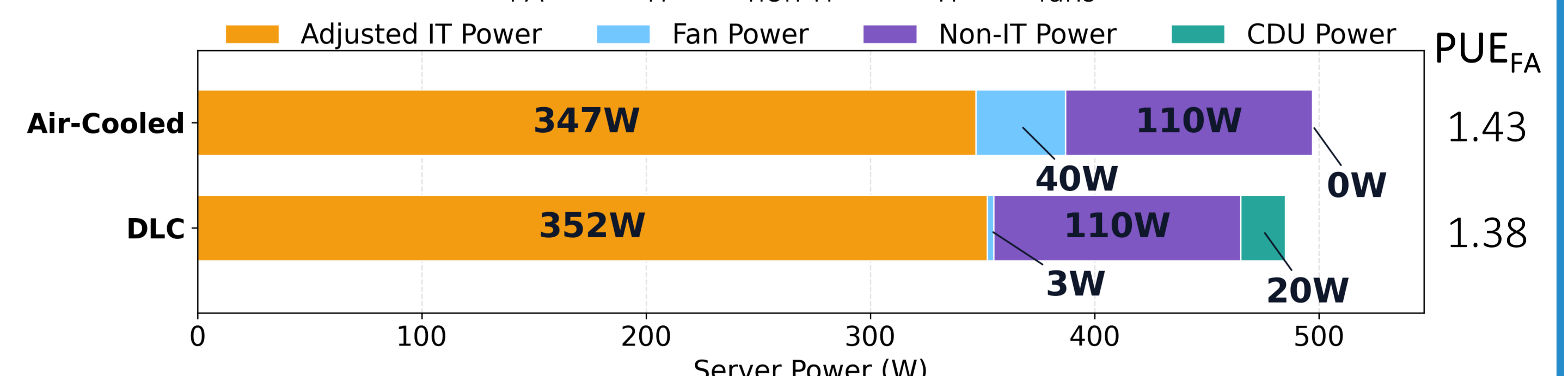

Server fans are used for cooling and should be non-IT power